

DESIGN

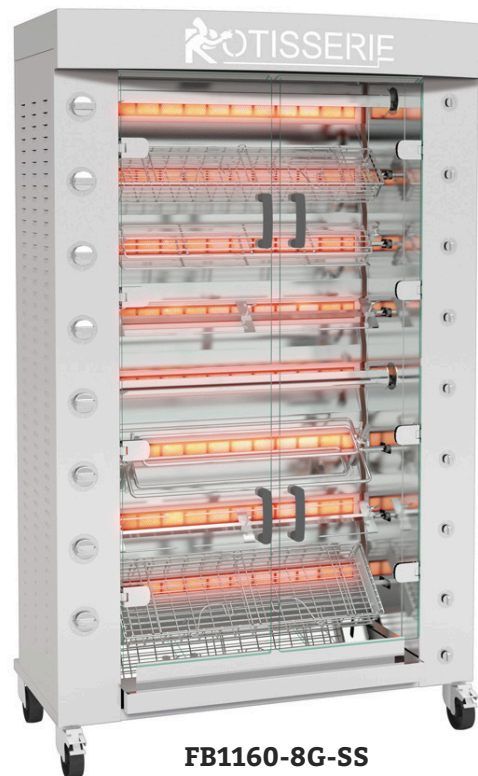





The FlamBoyant range of rotisseries has been especially designed for high-volume cooking with high output and speed, while retaining excellent cooking quality. Well designed, user friendly and reliable the FlamBoyant is used by leading supermarkets and chain restaurants throughout the world. Conscious of the high energy cost involved for our clients, the FlamBoyant rotisserie has energy saving infrared burners, patented by Rotisol. A wide array of accessories enable the rapid roasting of a variety of products.

FEATURES

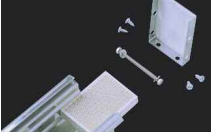
- Energy efficient
- Tempered K-glass doors
- Independent motor for each spit
- Equipped with bottom drip tray with built-in drainage
- Rotisol patented burners
- Powerful halogen lamp
- Delivered with 8 prongless spits (CUI)
- Base on casters with brakes

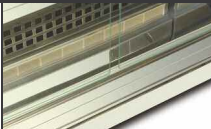

Overview of some of the standard features:

	Replaceable ceramic bricks for significant financial savings		Robust hinges designed for heavy use with integrated locking in open and closed positions		Gas safety! Separation of the gas and electric chambers avoids any risks of explosion.
	Gas and electric switches in chromed metal		Anti-scald K.Glass reduces external thermal radiation (energy saving). Glass overlaps drip pan to keep splatters inside (anti-slip protection).		Removable inside side-panels doubles protection from grease seeping into motors and other sensitive parts.

ACCESSORIES

A variety of accessories are available. See video of available accessories and of vertical spit system online.

CUI Anti-cutting prongless V-spit		BP Porchetta spit		BRC Regular basket spit	
BS Spit for ham/turkey		BRRO Roast-clamp spit		BA Lamb/suckling-pig	
BCR Spatchcock chicken basket.		DEC Spit mover		PID Tray for unspitting	

FRONT VIEW

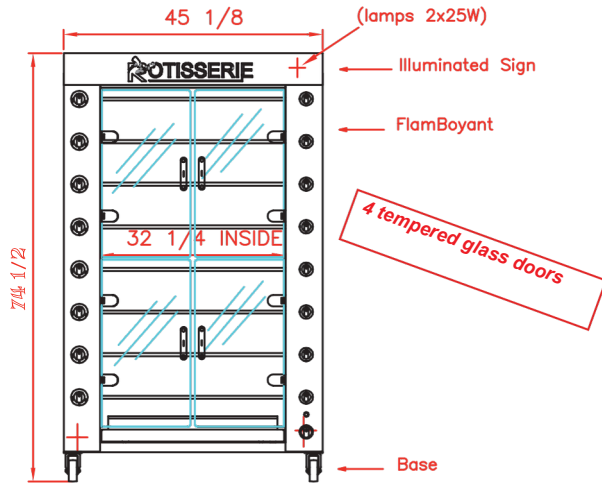

TOP VIEW

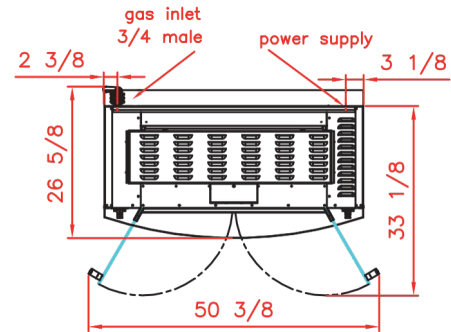

SIDE VIEW

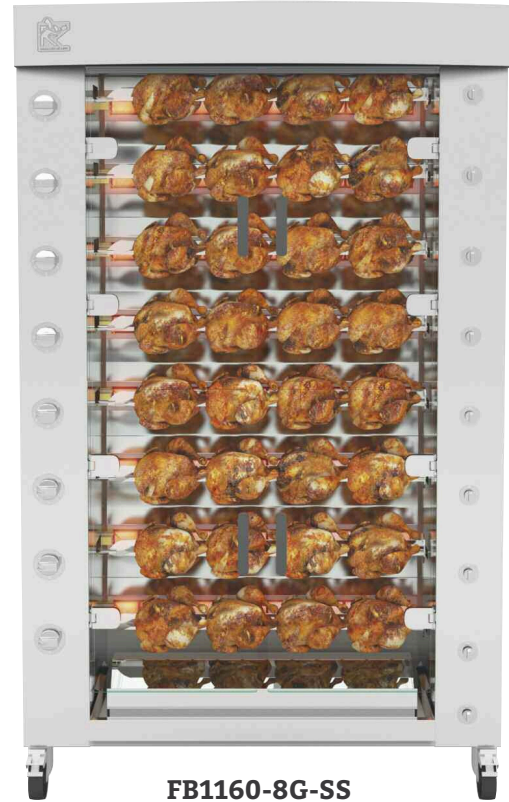
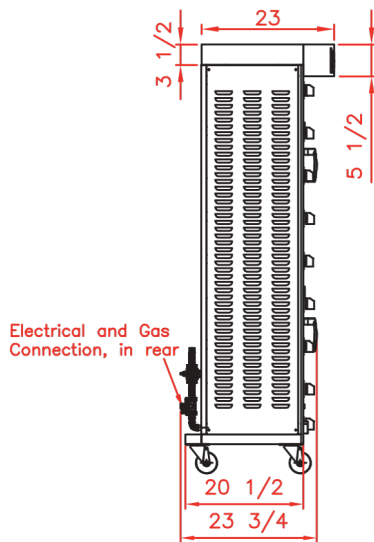

SPECIFICATIONS

Capacity	32/40 chickens
Gas Power	103000 BTU/h
Power Supply	208-240V ~60Hz; 3 Amps
Electrical Power	0,59 kW
Weight & Size (HxDxW)	430 lbs, 74 1/2 x 26 5/6 x 45 1/8 inches
Shipping Weight & Size	565 lbs, 78 3/4 x 29 1/2 x 47 3/8 inches
Warranty	1 year parts and labor

Rotisol USA

21618 Marilla St, Chatsworth, CA 91311, United States
info@rotisolusa.com - Phone: (310) 671- 7254

Origine / Origin Europe

