

Special Market BrasiliaE

DESIGN

The Brasilia features a unique cooking system that allows for the roasting of whole marinated chickens, grilled entirely using the so-called “CRAPAUDINE” method to offer a variety of styles and flavors.

This innovative rotisserie system doubles production volumes while reducing energy consumption by the same proportion.

FEATURES

- All stainless steel
- Visibility and accessibility from the front and back
- Reinforced shielded heating elements
- 4 K-glass panels
- Removable grease tray with built-in drain
- Halogen interior lighting



- 27 roasted chickens in 30 minutes
- Compact design thanks to optimized dimensions (shallow depth: 505 mm)
- Quick return on investment



BrasiliaE
stainless steel finish

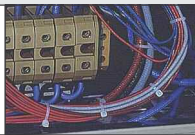

TECHNICAL SPECIFICATIONS

Overview of some standard features.

	<p>Shielded electric heating elements with linkage clamps..</p>		<p>Removable grease trap with built-in drain.</p>		<p>Easy and secure access to the compartment containing connectors and electrical components.</p>
	<p>Halogen interior lighting.</p>		<p>K-glass anti-scald glazing to reduce heat loss (energy savings).</p>		<p>Support bar for the open spit when placing chickens in the rotisserie or removing them.</p>

ACCESSORIES

A wide variety of accessories are available.

<p>BCRBRASIL Brooch «crapaudine».</p>		<p>DEC Pin Remover</p>		<p>AT Torch lighter.</p>	
---	---	----------------------------	--	------------------------------	---

Front view
Rotisserie
and wheeled stand

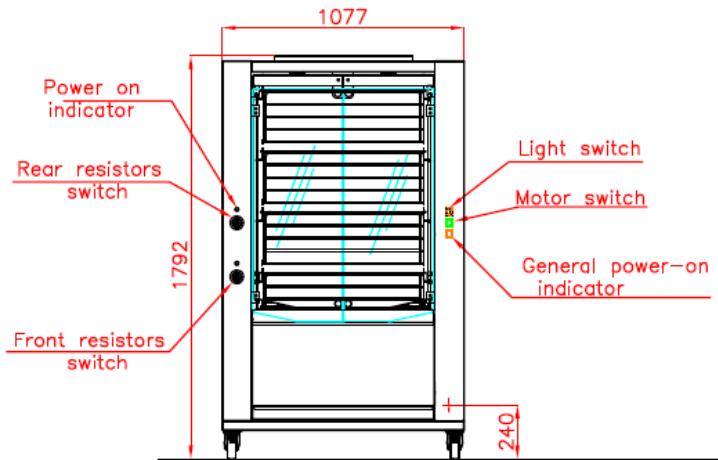

Top view
Rotisserie
and wheeled stand

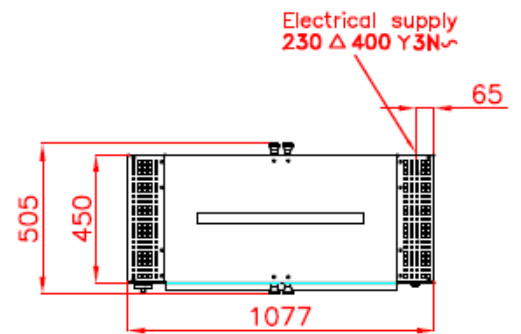

Side view
Rotisserie
and wheeled stand

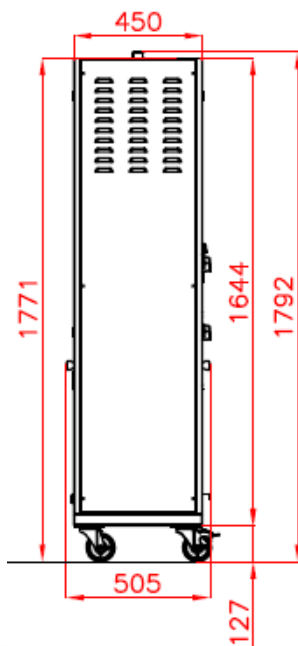

Révision :
Décembre 2020



BrasiliaE
stainless steel finish

SPECIFICATIONS

Capacity	27 crapaudines
Power supply	400 V 50/60 Hz + earth
Electrical power	12,38 kW
Weight and size (HxDxW)	180 kg ; 1792 x 1077 x 505 mm
Dégagement	80 cm in front and behind, 10 cm on the left and right
Garantie	1-year warranty on parts (excluding glass)

DISTRIBUTOR / AGENT

Rotisol S.A.S.

Zone industrielle La Trentaine, Avenue Gustave Eiffel
77507 Chelles cedex - FRANCE

FRANCE :- adv@rotisol.com - Tel : +33 1 64 21 80 00

EXPORT :- s.bennell@rotisol.com