

DESIGN & PERFORMANCE

Sleek and modern, the Star-Clean Rotisserie features elegant screen-printed glass doors that beautifully showcase your products as they cook under powerful interior lighting. Designed for both style and functionality, this robust unit delivers high output, fast cooking speeds, and exceptional roasting performance. Available as a front-load model with a closed back, it is fully insulated and equipped with energy-efficient heating elements, helping you save on both energy and costs. Effortlessly prepare a variety of proteins and vegetables while maintaining superior cooking quality.

CLEANING

Designed for convenience, this rotisserie features *advanced assisted cleaning technology, making maintenance effortless*. A powerful steam injection loosens cooking grease, followed by a high-pressure shower for a deep, thorough clean. The unit includes a removable tub for easy collection and disposal of cooking fat. For a spotless, streak-free finish, an optional Brita water softener can be added to prevent soak stains.

TOUCH CONTROL PANEL

- Large IPS touchscreen control panel
- 4 categories of pre-recorded programs
- Time and temperature programming
- Cleaning and maintenance menus
- 99 programmable recipes
- Alarm at the end of the cooking process and auto hold at 63°C for up to 2 hours
- Steam cleaning program



Touch Control

Multiple recipes + Wash function + manual control



Recipes

Multiple Preset and manual recipes (+ can add up to 99 programs)



SC5.560 + SC5.560MSTO (optional base cabinet)



TECHNICAL CHARACTERISTICS

- Energy-efficient heating element
- Fully insulated with rock wool (Bio-soluble aluminum encapsulation)
- K-Glass thermal double glazing mounted on silicone seal (anti-scald front panel)
- PVC 1/4 turn heat resistant locking door handle
- Halogen lighting
- Automatic cooling of heating turbines after switch off (safety of technical components)
- Integrated grease pan (multi functioning for cooking vegetables and more)
- Built in recipe library or design your own
- Easy drainage of grease pan directly into the removable tub
- Delivered with cooking baskets BAL560

ACCESSORIES

BG Grease tub + base with castors	BRITA2 Water softener	DOUCH High pressure nozzle for cleaning	MCF Oven cleaner	SAC Heat Resistant liner (grease collection)

ACCESSORIES (OPTIONAL)

BAL560 Basket for poultry	BAP560 Small cuts basket	PD560 Vegetable tray	PLC560 Cooking basket

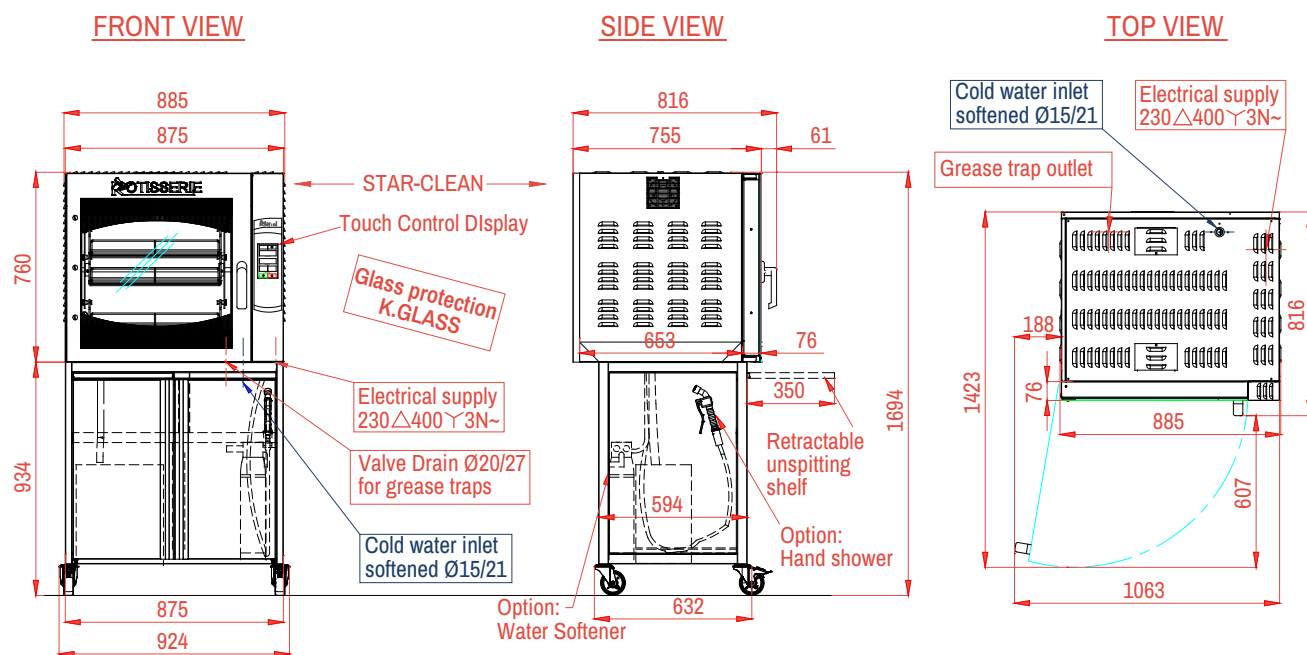

SPECIFICATIONS

Weight	170kg
Capacity of poultrys	15
Number of baskets	5
Doors	1 double glazed door (anti-scald K.Glass)
Internal lighting	Halogen lamps protected by glass cover
Power supply	3 Phase (230Δ400Y3N~)
Electrical power	7.5kW
Wire length	2m
Temperature and Time control	TOUCH Screen
Cooking cycle alarm	Yes
Cleaning cycle	Yes
Internal presentation	Central axis, support and removable baskets



SC5.560 + SC.PIED



Revised: March 2025



DISTRIBUTOR / AGENT

Rotisol S.A.S.

Zone industrielle La Trentaine, Avenue Gustave Eiffel

77507 Chelles cedex - FRANCE

s.bennell@rotisol.com - Tel : +33 1 64 21 80 00

www.rotisol.com

