



### Millenium

1375.2MLE/MSE + i

#### DESIGN

Rotisol's most popular line, the Millenium combines the beauty of elegant finishes with the highest degree of functionality and cooking quality.

A wide array of spits allow the chef to cook anything that can be roasted: whole or split chickens, lamb, beef roasts and steaks, cuts of pork, porchetta, fish, vegetables, even fruit.

The optional Vertical Spit System with its choice of eight hanging accessories expands the menu possibilities even more and adds additional visual appeal.

#### FEATURES

- Energy efficient
- Tempered K-glass doors
- Independent motor for each spit
- Equipped with bottom drip tray with built-in drainage
- Reinforced and anti warping heating element
- Powerful halogen lamps
- Delivered with 3 prongless spits (CUI1375)
- Illuminated sign «Rotisserie» for enamel model only
- Base on casters with brakes



1375.2MLE  
Black enamel and brass



#### TECHNICAL DETAILS

Overview of some of the standard features.

	Reinforced heating elements with stainless steel holders to keep them in place and removable stainless steel panels for easy cleaning.		Emergency stop button type «punch» easily accessible.		Easy and protected access to the compartment of connections and electrical components.
	Switches, in chromed or brass-colored metal		Anti-scald K-glass reduces external thermal radiation (energy saving). Glass overlaps drip pan to keep splatters inside (anti-slip rotation).		Removable inside side-panels doubles protection from grease seeping into motors and other sensitive parts

#### ACCESSORIES

A variety of accessories are available. See video of available [accessories](#) and of [vertical spit system](#) online.

<b>CUI1375</b> Anti-cutting prongless V-spit.		<b>BP1375</b> Chicken spit.		<b>BRC1375</b> Rectangular basket spit.	
<b>BS1375</b> Spit for ham / turkey.		<b>BRRO1375</b> Roast-clamp spit.		<b>BA1375</b> Lamb/suckling-pig spit.	
<b>BCR1375</b> Spatchcock chicken basket.		<b>DEC</b> Spit mover.		<b>PID1375</b> tray for unspitting.	

### Front view

Rotisserie with roof (optional)  
and base on casters (optional)

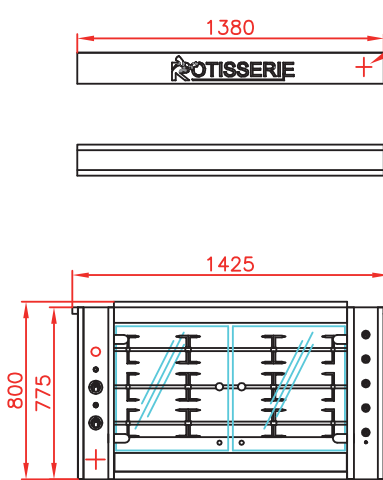

(lamps 2x25W)

Illuminated Sign  
(Optional)

Protective Roof  
(Optional)

GRANDES FLAMMES  
MILLENIUM

Electrical  
Connection, in rear

2 securit glass doors  
"K" system

### Side view

Rotisserie with roof (optional)  
and base on casters (optional)

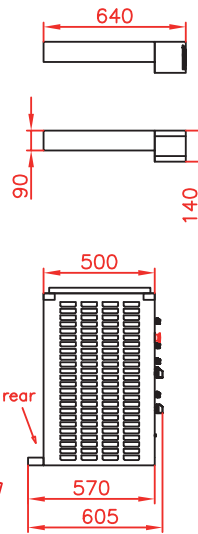

Caster Base  
(Optional)

Heated Base Cabinet  
(2,055kW)  
or  
Base Cabinet  
(Optional)

### Top view

Rotisserie with roof (optional)  
and base on casters (optional)

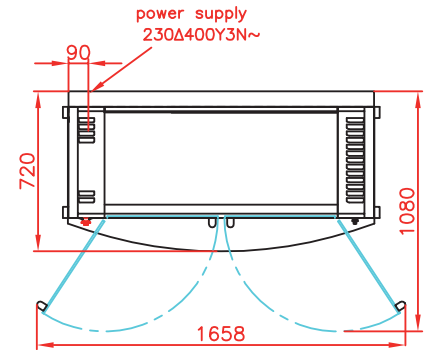

1375.2MSE

Stainless steel with black enamel and chrome



Revised :  
December 2016



## SPECIFICATIONS

Capacity	10/12 poultries
Power supply	400 Volts 3 phases+neutral+earth
Electrical power	12.85 kW
Weight and size (HxDxW)	170 kg ; 1625 x 720 x 1425 mm
Shipping weight and size	231 kg ; 1760 x 760 x 1500 mm
Guarantee	1 year parts

DISTRIBUTOR / AGENT

Rotisol S.A.S.

Zone industrielle La Trentaine, Avenue Gustave Eiffel

77507 Chelles cedex - FRANCE

[s.bennell@rotisol.com](mailto:s.bennell@rotisol.com) - Tel : +33 1 64 21 80 00

[www.rotisol.com](http://www.rotisol.com)