

### Special Market Brasilia.G

#### DESIGN

The Brasilia rotisserie line is dedicated to the unique spatchcock style cooking method, roasting whole butterflied chickens flavored with any choice of marinades or seasonings.

Spatchcock roasting is a perfect fit for any kind of ethnic market (Hispanic, Middle Eastern, etc.), while doubling your production volume and decreasing your energy consumption by half.

#### FEATURES

- All stainless steel unit
- Front and back visibility and accessibility
- Independent infrared gas burners with interchangeable ceramic bricks
- 4 K-glass doors
- Bottom drip tray with drainage tap
- Interior halogen lighting

- 27 chickens in 30 minutes
- Reduced gas consumption 9 spits = 41000 (btu/h)
- Compact design with optimized dimensions (shallow depth: 535 mm)
- Quick return on investment



Brasilia.G  
All stainless steel



#### TECHNICAL DETAILS

Overview of some of the standard features.

	<p>Replaceable ceramic bricks for significant financial savings.</p>		<p>Bottom drip tray with drainage tap.</p>		<p>Gas safety ! separation of the gas and electric chambers avoids any risks of explosion.</p>
	<p>Interior halogen lighting.</p>		<p>Automatic ignition of burners by a train of sparks.</p>		<p>Support bar for support of spit in open position, during the loading and unloading of chickens from the rotisserie.</p>

#### ACCESSORIES

A variety of accessories are available.

<p><b>BCRBRASIL</b> Spatchcock chicken basket.</p>		<p><b>DEC</b> Spit mover.</p>		<p><b>AT</b> Gas lighter.</p>	
--	--	-----------------------------------	--	-----------------------------------	--

**Front view**  
Rotisserie  
and base on casters

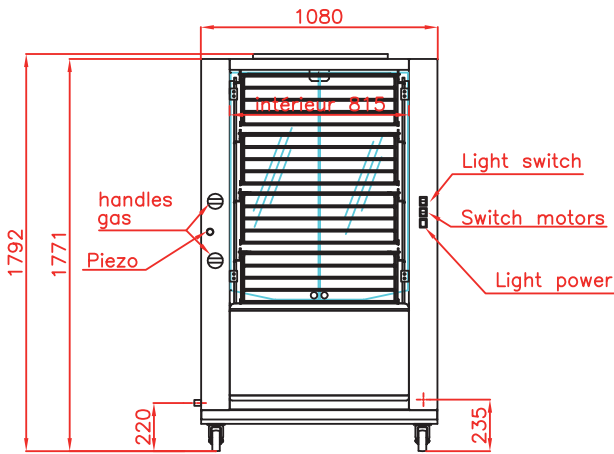

**Top view**  
Rotisserie  
and base on casters

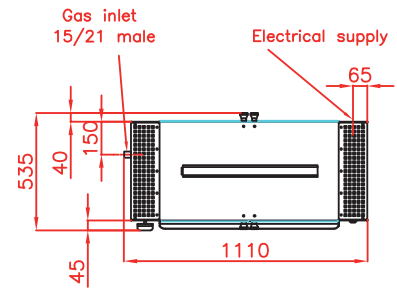

**Side view**  
Rotisserie  
and base on casters

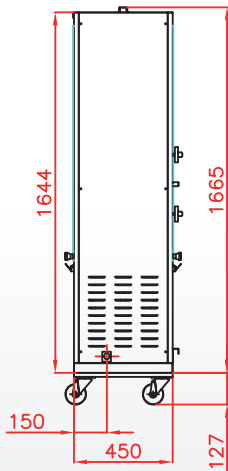

Revised :  
June 2021



Brasilia.G  
All stainless steel



## SPECIFICATIONS

Capacity	27 open poultries
Gas power	15 kW
Power supply	208-230V-50Hz/60Hz
Electrical power	0.23 kW
Weight and size (HxDxW)	165 kg ; 1792 x 535 x 1110 mm
Shipping weight and size	220 kg ; 1965 x 760 x 1225 mm
Guarantee	1 year parts

DISTRIBUTOR / AGENT

Rotisol S.A.S.

Zone industrielle La Trentaine, Avenue Gustave Eiffel

77507 Chelles cedex - FRANCE

[s.bennell@rotisol.com](mailto:s.bennell@rotisol.com) - Tel : +33 1 64 21 80 00

[www.rotisol.com](http://www.rotisol.com)