

### DESIGN & PERFORMANCE

Sleek, modern and built with durable stainless steel, the Roti-Roaster rotisserie combines elegance with functionality. Its "ROTISSERIE" screen-printed glass doors and powerful interior lighting beautifully showcase your products while they cook. Designed for efficiency, it features a front-load and rear door design, passthrough, for optimal performance.

Cleaning is effortless with removable accessories, interior panels, and a drip pan, ensuring convenience and hygiene. Engineered for high output, rapid cooking, and superior roasting, this rotisserie is built to last. Fully insulated with energy-efficient heating elements, it minimizes energy consumption while maximizing performance *helping you save on costs without compromising quality.*

### ENERGY & COST-EFFICIENT K-GLASS

Designed for superior energy efficiency, the Roti-Roaster features insulated, double-glazed K-GLASS doors. The inner pane is coated with a specialized thin metal layer that regulates heat transfer, providing exceptional resistance to thermal radiation. This advanced design reduces energy consumption, lowers operational costs, and maximizes savings.

Additionally, K-GLASS minimizes heat emission in the kitchen, creating a cooler and more comfortable workspace for your team. The enhanced insulation also improves safety by preventing burns upon contact with the door surfaces, ensuring a secure cooking environment.



FBPT5.360 + FBP5.360MSTO (optional base cabinet)



### CONTROL PANEL



Standard (Default)

With 6 preset programs  
+ manual control

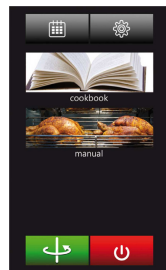

Touch (Optional)

Multiple recipes + manual control  
(+ can add up to 99 programs)

### TECHNICAL CHARACTERISTICS

- Fully insulated with rock wool (Bio-soluble aluminum encapsulation)
- K-Glass thermal double glazing mounted on silicone seal (anti-scald front panel)
- Control panel with 6 cooking programs
- Delivered with cooking baskets BALD320
- Enters auto hold at the end of the cooking cycle

### ACCESSORIES (OPTIONAL)

BALD320 Basket for poultry	BAP320 Small cuts basket	PD320 Vegetable tray	PLC320 Cooking basket	BCRA320 Spatchcock spit	BV320 Chicken spit (fork)

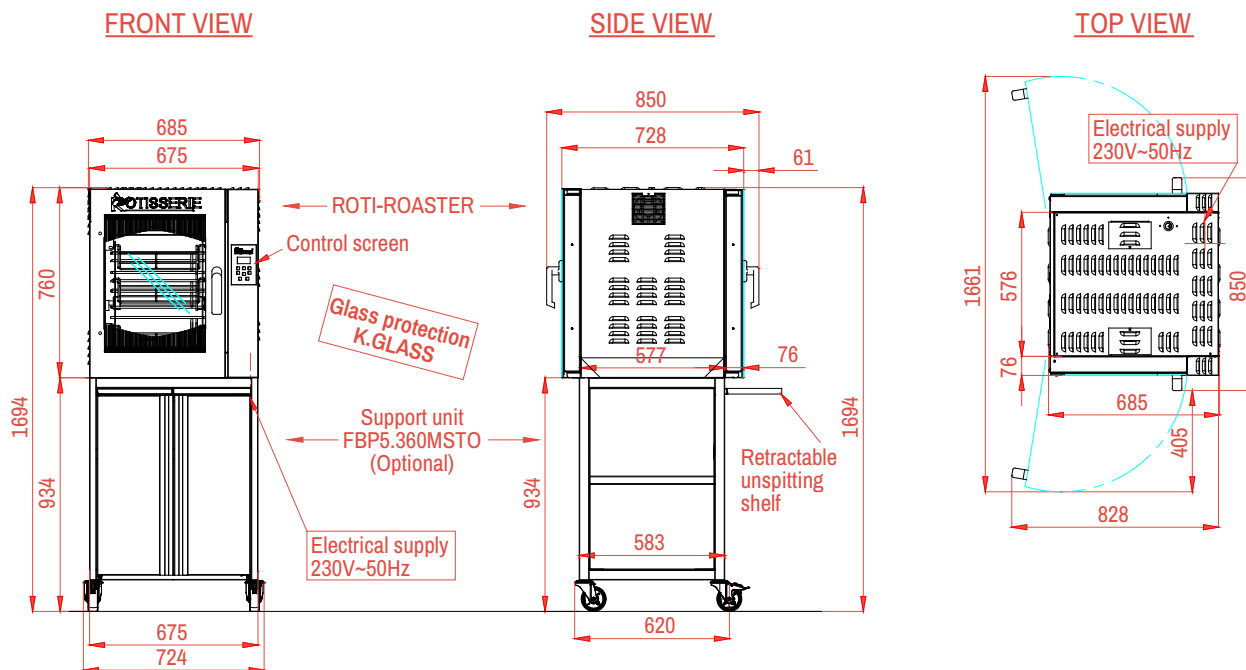

## SPECIFICATIONS

Weight	105kg
Capacity of poultrys	5 / 10
Number of baskets	5
Doors	2 double glazed door (anti-scald K.Glass door)
Internal lighting	Halogen lamps protected by glass cover
Power supply	1 Phase (230V~50Hz)
Electrical power	4kW
Wire length	2m
Temperature and Time control	Digital control or optional TOUCH Screen
Cooking cycle alarm	Yes
Internal presentation	Central axis, support and removable baskets



FBPT5.360 + FBP.PIED



Revised: March 2025



DISTRIBUTOR / AGENT

**Rotisol S.A.S.**

Zone industrielle La Trentaine, Avenue Gustave Eiffel

77507 Chelles cedex - FRANCE

s.bennell@rotisol.com - Tel : +33 1 64 21 80 00

www.rotisol.com

